

Towards Recovering Architectural Information from Images of Architectural Diagrams

Emmanuel Maggiori¹, Luciano Gervasoni¹, Matías Antúnez¹,
Alejandro Rago², and J. Andrés Díaz Pace²

¹ Facultad de Ciencias de Exactas, UNCPBA, Campus Universitario,
(B7001BBO) Tandil, Buenos Aires, Argentina.

{emaggiori, lgervasoni, mantunez}@alumnos.exa.unicen.edu.ar,

² ISISTAN Research Institute, CONICET-UNICEN.

{arago, adiaz}@exa.unicen.edu.ar

Abstract. The architecture of a software system is often described with diagrams embedded in the documentation. However, these diagrams are normally stored and shared as images, losing track of model-level architectural information and refraining software engineers from working on the architectural model later on. In this context, tools able to extract architectural information from images can be of great help. In this article, we present a framework called IMEAV for processing architectural diagrams (based on specific viewtypes) and recovering information from them. We have instantiated our framework to analyze “module views” and evaluated this prototype with an image dataset. Results have been encouraging, showing a good accuracy for recognizing modules, relations and textual features.

1 Introduction

Software architecture knowledge is an important asset in today’s projects, as it serves to capture and share the main design decisions and concerns among the project stakeholders. Briefly, the software architecture is a model for describing the high-level organization of a system (since early development stages) [1]. More specifically, the architecture encompasses the set of structures needed to reason about a computing system, which comprises software elements, relations among them, and properties of both. The architecture can be documented using different mechanisms, for instance: Word documents, sketchy notes, UML diagrams within a CASE tool, or Web pages hosted in a Wiki, among others [6,9].

The notion of *architectural views* is key in documenting software architectures [4]. A view presents an aspect or viewpoint of the system (e.g., static aspects, runtime aspects) by means of textual and graphical contents. Typical examples of views are: module views (the units of implementation and their dependencies), component-and-connector views (the

elements that have runtime presence and their pathways of interaction), or allocation views (the mappings of software elements to hardware). A common practice in software projects is to have architectural diagrams as the main source of documentation. These diagrams are kept as images (e.g., JPG files) and pass them along as the development process progresses embedded in textual documents (even if the diagrams were originally created with a CASE tool). As a result, the model-level information contained by the diagram is “frozen” in the image format. This is a problem if engineers later need to work on the architectural model. Typical activities (or needs) include: i) updating the diagram, because the original model file is lost; ii) establishing traceability links with other models, often in a semi-automated fashion; or iii) feeding the model back into (other) CASE tools, among others.

In this context, we argue that tools able to extract design information from architectural diagrams can be of great help to software engineers. In fact, the areas of image recognition and classification have greatly evolved over the last years, and advanced techniques for analyzing graphical documents have been developed for engineering domains such as: patents, architectural drawings, circuit designs and flowcharts, among others. However, to the best of our knowledge, only a few applications of these techniques to UML models have been reported [10,12,14]. In this work, we present an image extraction framework, called *IMEAV (Image Extractor for Architectural Views)*, that is targeted to architectural views. Our framework takes advantage of the distinctive characteristics of a given architectural view (also referred to as its *viewtype*) in order to derive a view-specific processing pipeline. This pipeline is then able to read images and generate a graph-based representation of the view constitutive features as detected in the image (e.g., box types, edges connecting the boxes, edge types, text associated to either boxes or edges, etc.). An instantiation of the framework for the specific case of module views is presented. A preliminary evaluation with a sample of images of module views has shown an encouraging detection performance.

The rest of the article is structured into five sections. Section 2 discusses related work on image processing techniques applied to diagram recognition. Section 3 introduces the IMEAV framework, its main building blocks and supporting techniques. Section 4 describes an implementation for the detection of module views. Section 5 presents the results of evaluating the detector of module views. Finally, Section 6 gives the conclusions and discusses future work.

2 Related Work

The problem of document analysis and recognition has been of wide interest to the scientific community for decades [17]. Most works have addressed the recognition of specific patterns independently. Particularly, great efforts have been done in character recognition [8], text line segmentation [15] and line detection [13]. For text detection, however, many works have relied on third-party character recognition (OCR) packages, such as Tesseract and Abbyword [16,19,21]. Extracting each of these elements separately is a different problem to the analysis of graphical documents, given that in the latter all these patterns co-exist.

Patent copying and plagiarism is a relevant area in which different proposals for diagram analysis have been presented [3]. In this domain, graphical descriptions play a crucial role to verify the originality of patents. Several patent retrieval systems were developed for indexing and searching in the documents, based on a prior analysis of the raw image data (generally, paper-scanned images). Another works have alternatively focused on recognizing flowcharts within patents [16,19,21].

Although many of the techniques defined in the works above can be adapted to the domain of architectural diagrams, there are some differences in patent schemas that prevent a straightforward application to Software Engineering. For instance, architectural diagrams commonly organize elements in a hierarchical fashion, allowing child elements to be connected with external elements, and hence criss-cross with the parent element [19]. On the contrary, some particularities of flowchart recognition are not a major concern in the architectural domain, especially processing diagrams sketched by hand. This fact minimizes the need to include heavy noise reduction, deskewing and brightness correction mechanisms.

Specific to Software Engineering, Karasneh and Chaudron have presented *Img2UML*, a tool to reverse-engineer UML class diagrams from CASE-generated images [12]. Furthermore, the works in [10,14] describe tools able to recognize UML class diagrams sketched by hand on paper or whiteboards. Despite their resemblance with architectural views, class diagrams are different in several aspects: the shape of the compartments is unequivocal, the appearance of typed relations is distinctive one another (allowing to distinguish associations from generalizations easily), among others. Architectural diagrams are more flexible in terms of drawing conventions, in the sense that different architects can sketch architectural concepts with similar but not exactly equal shapes.

3 General Approach

We propose an integral approach called IMEAV for assisting software engineers in the recovery of model-level information held in images, such as nodes, relations and accompanying text. IMEAV is designed as an image recognition framework customized for architectural diagrams, which consists of an arrangement of *recognition/extraction components* that can be flexibly configured in order to process different architectural viewtypes. For instance, Fig. 1 shows inputs to our framework for the case of module views. Note that the diagrams include features such as boxes, arrows connecting boxes, text and a hierarchical layout (containers), among others. The goal of IMEAV is not to develop sophisticated or novel image recognition algorithms, but rather to leverage on existing algorithms/libraries as the “building blocks” for constructing specialized processing pipelines that can be used by software engineers in their daily architectural work.

Our framework accepts various image formats as inputs. The only consideration for the input image is that its constituents should adhere, to a certain degree, to the vocabulary and rules of a valid architectural viewtype. The viewtype must be predefined when the framework is configured and selected (only one) before it begins its processing. To this end, we assume the viewtypes defined by Views and Beyond [4], namely: modules, components and connectors, and allocation. These viewtypes are compliant with the ISO/IEC 42010, provided that the information requirements of the standard are fulfilled in the corresponding architecture document [4]. Although IMEAV is expected to be robust and tolerates some “noise” or elements not belonging to the target (chosen) viewtype (see Fig. 1a, or even Fig. 1b that mixes elements from a component-and-connector view), the closer the image to the viewtype vocabulary, the better the recognition results.

From a blackbox perspective, the output of IMEAV is a graph with nodes and edges, both possibly decorated with textual annotations. This representation fits well with the general structure of architectural viewtypes, which are described by a collection of element types, relation types, and properties. Furthermore, this graph representation can be easily converted to UML or XML formats, for instance XMI³. Fig. 2 shows a possible output graph generated with IMEAV for the diagram of Fig. 1a. In the figure, a graph node is labeled with the properties *type*=“*module*” and *name*=“*Server*” after analyzing a box in the image that corresponds to a module. A graph edge is created with the properties *type*=“*usage*” and

³ <http://www.omg.org/spec/XMI/>

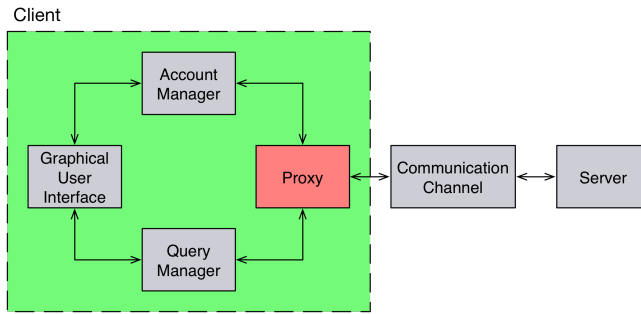

(a)

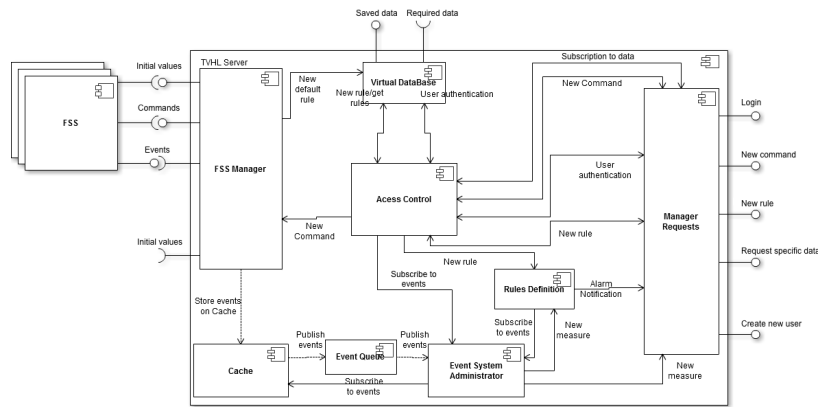

(b)

Fig. 1. Some sample items of our dataset of module diagrams: (a) Non UML-compliant, (b) UML-compliant.

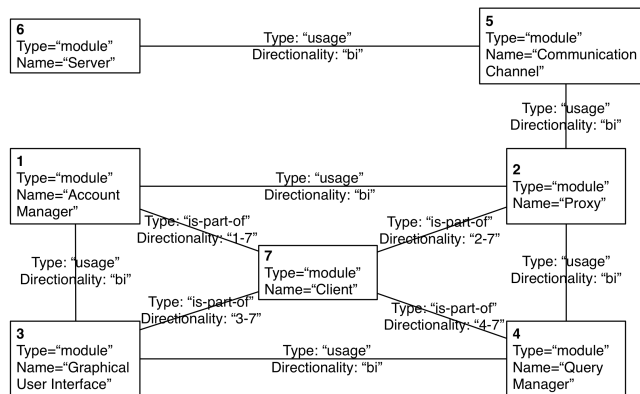

Fig. 2. Output graph for the module view diagram of Fig. 1a

directionality=“*bi*” based on the detection of a bi-directional arrow connecting two module boxes. However, this does not mean that our framework will always identify all the features present in a diagram. It might happen that, after running IMEAV, some view-related information goes undetected and thus missing in the output graph. Examples of such situations might be: (i) the tool properly recognizes a module and its arrows, but fails to infer the box type; or (ii) certain image regions are difficult to process and produce mistakes that might be carried along the pipeline.

The design of our framework follows a pipe-and-filter architecture [1], according to the general workflow depicted in Fig. 3. The workflow divides the processing system into 5 configurable phases, namely: preprocessing, separation of text/structure, element extraction, relation extraction, text recognition and graph assembly. Each of these phases is explained next.

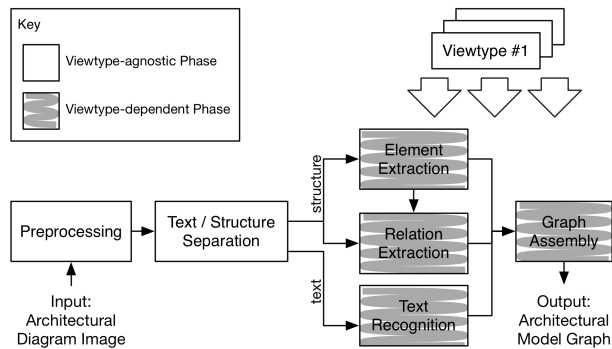

Fig. 3. The IMEAV processing pipeline and the role of architectural viewtypes

The *Preprocessing* phase prepares the image for more complex analyses. This usually includes making a conversion from color to gray scale, but it also allows making additional corrections to the image. For example, corrections such as denosing or deskewing are convenient to avoid mistakes in later phases. The *Text/Structure Separation* phase aims at separating the input into two distinct layers: one containing the text and another one keeping the structural elements (e.g., boxes, arrows). This procedure, although common for document analyses, is not trivial to perform. In general, the separation is implemented in a dedicated component [19], relying on techniques like blob analysis, anisotropic filtering and perceptual grouping, among others [15].

The first two phases of IMEAV are agnostic with respect to the target architectural viewtype. The following phases are affected by the vocabulary of the architectural viewtype chosen for the pipeline (e.g. modules view). The *Text Recognition* phase recognizes characters from text areas of the image. For this reason, having a (prior) good separation between text and structures is important. The identification of textual characters is often delegated to third-party OCR implementations, which take a bounded image portion and produce a set of characters [8].

The *Element Extraction* phase detects elements such as modules, nodes and other architectural concepts, by scanning the boxes in the image. This procedure is not simple, because elements do not necessarily have a one-to-one mapping to geometric shapes. For example, UML modules are represented with boxes that have a small (contiguous) rectangle atop, that is, a combination of two geometrical elements (see Fig. 1b). For this reason, we usually divide this phase into two tasks: (i) extraction of geometric entities (typically, rectangles) that satisfy a number of conditions, and (ii) identification of the actual elements, based on the precedent results. The second task can be accomplished by combining shapes via *ad-hoc* procedures or using Machine Learning techniques (see Subsection 4.4 for a specific example).

The *Relation Extraction* phase reveals relations that connect elements. This phase is again divided into two tasks: (i) extraction of relevant geometric shapes (e.g., line segments), and (ii) identification of the underlying connecting paths from sets of shapes (e.g., a relation can be formed by a sequence of line segments). Additionally, this phase also analyzes the endpoints of connection paths because they are key to determine the type of relations. To this end, this phase not only works with information from relation-related shapes, but also takes advantage of information about the elements recovered in the previous phase. By relying on elements to determine relation types, non-existing relations can be filtered out [16] (e.g., excluding line segments that are part of elements in the image).

Finally, the *Graph Assembly* phase has the purpose of combining the outputs of previous phases and constructing a graph representation that contains a “reverse-engineered” model of the input image (see Fig. 2). This phase comprises tasks such as: deciding to which feature each textbox will be coupled by evaluating the element hierarchy, associating relations to elements, or linking relations with their descriptors.

4 The Case of Module Diagrams

We have instantiated IMEAV with module views as the target viewtype. The main elements are *modules*. A module is an implementation unit that provides a coherent set of responsibilities. Modules might take the form of a package, a class, or a layer, among other shapes. Possible relations among modules are: *is-part-of*, *uses* or *is-a*. The relation *is-part-of* can be alternatively represented by a hierarchical containment of modules. Although module views can be easily represented with UML notation, non-standard shapes can be used in the diagrams as well (see in Fig. 1a and 1b). Our processing pipeline is robust enough to support the recognition of both UML and non-UML module diagrams as input images (or even "borderline" images, as in Fig. 1b).

In the following sub-sections, we describe how the phases of Fig. 3 were adjusted to work with module views. The current implementation is based on the OpenCV⁴ toolkit, which provides built-in support for connected component analysis, morphological and image handling operations.

4.1 Preprocessing

The preprocessing phase simply converts color to grayscale following a linear combination of the channels. Additionally, this phase also adds a one-pixel wide external border around the image with the color of its background. This border is for separating elements/relations that are contiguous to the image frame.

4.2 Text/Structure Separation

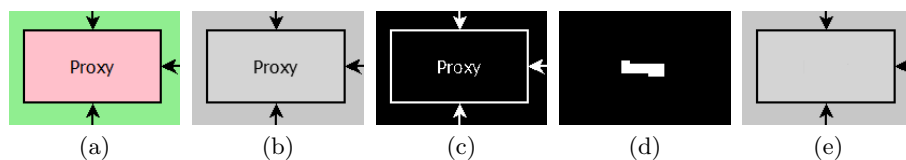

Fig. 4. A fragment of the diagram in Fig. 1: (a) Original, (b) Preprocessed, (c) Binarized, (d)-(e) Text/structure separation.

We use a blob-based analysis algorithm to separate text from structures [19]. First, the image is transformed with a binarization technique,

⁴ <http://opencv.org>

simplifying the extraction of blobs. The text and structures are separated using an absolute threshold binarization (because text is illustrated with dark colors) and a set of blobs is produced. Next, the blobs are filtered, leaving out only those blobs that are potential (individual) characters and excluding structure and relation boundaries. Then, a morphological closing is performed in order to unify nearby blobs and close the holes [7]. This procedure is done horizontally, since this is the usual layout of module views. Finally, the results of morphological closing are filtered to remove blobs of inappropriate dimensions. Once text areas are detected, elements are filled up with the highest foreground intensity and stored on a separate layer. Fig. 4 shows this algorithm on a fragment of Fig. 1a.

4.3 Element Extraction

To extract elements of module views, we implemented a number of dedicated components. First, the image is preprocessed using a binarization technique. We avoided using an absolute global thresholding technique for analyzing pixel intensities, since intensities belonging to foreground and background objects might overlap and thus a global threshold will induce in a loss of important information. Furthermore, deciding what constitutes a foreground or background pixel is not straightforward [21]. For these reasons, we developed a custom component that tags each pixel into one of two classes: *foreground* and *background*.

Our binarization component relies on a flood-filling algorithm. This algorithm performs an incremental addition of similar points to the blobs, with a given tolerance. Blobs that surpass a predefined threshold are tagged either as black or white. When a blob is tagged as white, a thin contour of black pixels is added around the blob. This is because sometimes this contour might not exist. For instance, in Fig. 1a the big box has a different color than its container, but there is not a continuous black boundary surrounding it. The addition of a black contour when turning the blobs into white ensures that the boundary between every feature will be preserved. Our binarization component takes special care for shadows whose gradient produces a large number of contiguous thin blobs. Black contours are only added when the blobs enclose a minimum area, so as not to paint chaotic boundaries in shadowed regions.

Once the binarization is done, a second component finds rectangular blobs in the (binary) image. To this end, we implemented an algorithm that computes the rectangularity index of each blob (area of blob / area of minimum enclosing rectangle) and then decides which ones are actually

rectangles using a threshold value (for the index). To address the detection of modules contained in other modules (see Fig. 1a), we applied an incremental analysis of the rectangles. In every iteration, the rectangles detected using the index are dilated (i.e., removed) so that contiguous regions are progressively unified, revealing new rectangles. This analysis is repeated until no further rectangles are left. After all rectangles are detected, contiguous rectangles get grouped into the output elements, so as to reveal the modules. Fig. 5 exemplifies the whole extraction phase.

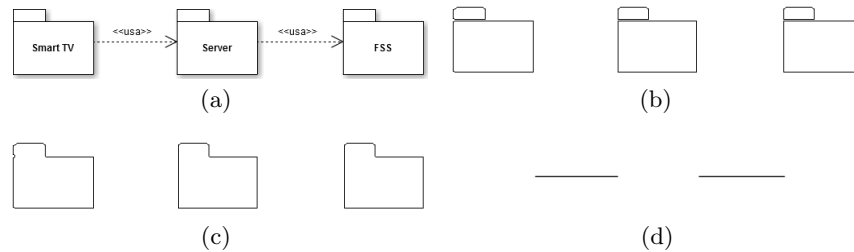

Fig. 5. Node extraction: (a) Original diagram, (b) Detected rectangles, (c) Detected modules, (d) Line-segment extraction

4.4 Relation Extraction

In module views, relations are represented with dashed/continuous paths composed of one or more line segments and with arrows at the endpoints. The lines can follow horizontal, vertical or oblique trajectories. In this context, we needed a technique able to identify line segments and then to group close-by lines into paths. For the detection of line segments, we relied on Hough's transform, an algorithm that supports the identification of both oblique and dashed lines [13]. Since line segments in binary images are usually thick, Hough's transform over-segments the image and produces a large number of candidate lines. Therefore, the results of Hough's are filtered to discard spurious lines using the information of the rectangles detected previously. Fig. 5d shows the results of applying Hough's transform to Fig. 5a, with the relations (dashed lines) correctly detected.

To extract relations out of line segments, we devised an algorithm that computes multi-segment paths. First, we store the endpoint positions of individual segments. After sorting segments by their length, we select the most prominent one and start looking for continuations of that segment (probably in another direction). To do so, we analyze every other

endpoint, seeking for nearby segments and consider the closest ones on a proximity basis (using a window size parameter). From all candidate segments, we select the longest one whose angle is beyond a given threshold, so as to keep moving along the path.

After detecting the paths, we have to analyze the endpoints. With this purpose, we applied a Machine Learning technique to classify endpoints according to their shape (e.g., arrow, line, diamond). In order to train the classifier, we first need a suitable representation for endpoint shapes compatible with classification algorithms. We chose to use Hu’s shape transformation instead of a pixel-wise conversion for robustness. Hu’s transformation defines 7 features of a shape that globally constitute a rotation and scale invariant descriptor [11]. We assembled a dataset of endpoints using Hu’s features and tagged them manually. This dataset was inputted to a Bayesian classifier⁵ for training, and the classifier was used to predict the shape of the endpoints.

4.5 Text Recognition

Following the separation of text and structures, our instantiation attempts to “read” the text boxes detected earlier by invoking an OCR system called Tesseract [20]. Tesseract is an open-source OCR engine that can process different image types and identify the text in them. Tesseract makes two passes on the images and uses an adaptive classifier trained on over 60.000 samples. The accuracy of Tesseract is good enough for processing CASE-generated images, thus suiting our purposes well.

4.6 Graph Assembly

Finally, after all the image analyses are concluded, we developed a component for creating a graph-based representation of the module view. To compute the information of the underlying model of the diagram, we followed a series of steps. First, a hierarchy of modules is constructed by observing those that contain other modules and those contained by another module. Then, modules and relations are linked. Three constraints are verified for this linkage, namely: (i) the distance between the extreme of a relation and a module must be lower than a pre-defined threshold; (ii) a relation is only valid if it connects two different modules; and (iii), no module has to include the other ones following the hierarchy.

Next, text boxes are associated with whatever module/relation they belong to. To do so, the distance from the center point of each text box

⁵ http://docs.opencv.org/modules/ml/doc/normal_bayes_classifier.html

to modules (and relations) are computed, and then the text boxes are associated with the closest module (or relation) found.

The graph representation progressively emerges from the features extracted with the different components of the pipeline. Our implementation currently outputs the graph in DOT⁶, a standard format which can be easily visualized with a number of tools (e.g. Graphviz). Fig. 2 shows a graphical representation of a sample module view.

5 Experimental Evaluation

To assess the performance of our pipeline for module diagrams, we tested it with a dataset of images⁷. This dataset was collected from two sources: (i) software architecture documents produced by students of a Software Design course taught at UNICEN University, and (ii) paper-scanned diagrams from an architecture documentation book [4]. The dataset comprises 60 heterogeneous diagrams, of which half of them are UML-compliant. The processing of each image took around 2 seconds (in average), running on a notebook with an Intel I7 2.2 GHz processor and 4Gb RAM memory, under a standard OS. The performance of systems like IMEAV is generally determined by evaluating each phase separately [21]. Specifically, we were interested in the accuracy of the module-view pipeline for element/relation extraction, text recognition and graph assembly.

Precision and recall measures were employed to gauge the quality of detection. To decide whether a particular image constituent was correctly detected, we analyzed the results after completing the *Graph Building* phase. This means that a relation is considered as a true positive if, besides being detected by the relation extractor, it connects the modules affected by it. A similar reasoning is followed for modules and text properties. Since some phases are executed sequentially, we took into account error propagation throughout the pipeline. In the case of relations, because their detection depends on the (correct) identification of modules, we consider an undetected relation as a false negative only when its associated modules were correctly spotted. Analogously, we consider an incorrectly-detected relation as a false positive only if it connects modules that were correctly detected. Thus, we tested the relation extractor only when the module extractor worked properly. Table 1 summarizes the results obtained in the experiments. In the table, n is the population of modules/relations considered for analyzing the results, which in the

⁶ <http://http://www.graphviz.org/doc/info/lang.html>

⁷ Available for download at: www.exa.unicen.edu.ar/~arago

case of relations is a subset of the total amount. Results are organized into two categories, differentiating those images with UML and non-UML features. We also included overall detection results.

Table 1. Accuracy of module and connector extraction

Module	n	Recall	Precision	Relation	n	Recall	Precision
non-UML	194	96%	98%	non-UML	140	63%	89%
UML-compliant	195	97%	95%	UML-compliant	126	66%	88%
Overall	389	97%	96%	Overall	266	64%	88%

IMEAV was very precise for separating text and structure. We only found problems in some cases where the text areas “touched” other modules or relations. The module detection obtained high recall and also high precision (97% for both), meaning that the pipeline succeeded at identifying the majority of the modules. Yet, we observed issues with some images. On one hand, false negatives came from unclear or broken edges (see an example in Fig. 6a). On the other hand, false positives came from overlapping relations that were mistakenly identified as modules, because their intersection points formed a rectangular shape (see Fig. 6b).

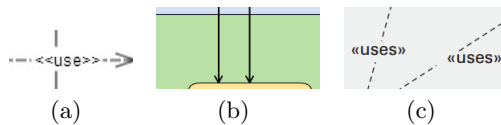

Fig. 6. (a) Interrupted edge, (b) Rectangular areas, (c) Interrupted connectors

The detection of relations showed acceptable results, but it was not on a par with that of modules. Although the precision was good (90%), the recall was merely sufficient (65%). These results are similar to those reported by other researchers [21]. An in-depth study of the results revealed many false positives when analyzing relations composed of multiple line segments. Especially, we found that the proximity constraint was not robust enough for detecting relations, because it does not take into account their direction. We also discovered that Hough’s transform had some issues with gap-filling tolerance (needed for dashed lines), in which the lines went beyond the limits of the relation and extended to modules or even to other relations. This aspect poses a trade-off between over-segmentation and precision that should be further studied. To a lesser

extent, false negatives were caused by text that overlapped with lines (Fig. 6c). Similarly to the discussion of dashed lines, the number of false positives depends on how over-segmentation was dealt with. For the detection of relation types, a 10-fold cross validation was run when evaluating the Bayesian classifier with Hu’s discretization. We considered two types of module relations: unidirectional and bi-directional. The classifier achieved a precision of 88% for directional endpoints and 79% for unidirectional endpoints. When it comes to attaching text to its corresponding module/relation, 89% and 85% of the text areas were correctly associated for UML and non-UML diagrams, respectively.

Overall, the results showed that our pipeline was able to effectively reverse-engineer module views “as a whole”, in spite of some difficulties with the detection of relations. Furthermore, the pipeline behaved almost equally in both UML and non-UML diagrams, corroborating the robustness of the implementation.

6 Conclusions and Future Work

In this article, we have presented a fast and automated approach for recovering model-level information from architectural diagrams stored in static images. Our IMEAV framework defines a processing pipeline that is driven by architectural viewtypes. The pipeline is made of generic phases, which must be tailored to the vocabulary of the target viewtype. As a proof-of-concept, IMEAV was exercised with a special pipeline for module views. In this experience, we were able to reuse several components from OpenCV, but still implemented a few dedicated components for the viewtype. So far, modules are the only viewtype supported by IMEAV, but we will extend the framework with viewtypes for components-and-connectors, and for allocation.

We ran some experiments with a dataset of module diagrams, and the pipeline for module views showed promising results. This evaluation also revealed some limitations of the approach. For instance, the detection of relations between modules was sometimes incorrect, due to over-segmentation issues. Also, the distinction of endpoint types was not perfect, even though we only considered two relation types. We expect to alleviate these limitations as we refine our framework with more detection/extraction components, and also using IMEAV to process other types of architectural diagrams. Furthermore, our future work will be oriented to apply the framework to a number of SE domains currently under research in our faculty. To name a few interesting applications, we plan to

identify architectural patterns and rules out of the graph-based representation [2], improve Wiki-based assistants for architectural documentation [5], and use the knowledge of architectural views to recover traceability links to requirements and source code [18].

References

1. Bass, L., Clements, P., Kazman, R.: Software architecture in practice. Addison-Wesley Professional (2012)
2. Berdún, L., Díaz-Pace, J.A., Amandi, A., Campo, M.: Assisting novice software designers by an expert designer agent. *Expert Syst. Appl.* 34(4), 2772–2782 (2008)
3. Bhatti, N., Hanbury, A.: Image search in patents: A review. *International Journal on Document Analysis and Recognition (IJDAR)* 16(4), 309–329 (2013)
4. Clements, P.: Documenting Software Architectures: Views and Beyond. Addison-Wesley (2003)
5. Díaz-Pace, J.A., Nicoletti, M., Schiaffino, S., Villavicencio, C., Sanchez, L.E.: A stakeholder-centric optimization strategy for architectural documentation. In: LNCS: Model and Data Engineering, vol. 8216, pp. 104–117. Springer Berlin (2013)
6. Farenhorst, R., Izaks, R., Lago, P., van Vliet, H.: A just-in-time architectural knowledge sharing portal. In: WICSA’08. pp. 125–134. IEEE (2008)
7. Gil, J., Kimmel, R.: Efficient dilation, erosion, opening, and closing algorithms. *IEEE Trans Pattern Anal Mach Intell* 24(12), 1606–1617 (2002)
8. Govindan, V., Shivaprasad, A.: Character recognition—a review. *Pattern recognition* 23(7), 671–683 (1990)
9. de Graaf, K.A., Tang, A., Liang, P., van Vliet, H.: Ontology-based software architecture documentation. In: WICSA’12. pp. 121–130. IEEE (2012)
10. Hammond, T., Davis, R.: Tahuti: A geometrical sketch recognition system for uml class diagrams. In: SIGGRAPH 2006. p. 25. ACM (2006)
11. Hu, M.K.: Visual pattern recognition by moment invariants. *Information Theory, IRE Transactions on* 8(2), 179–187 (1962)
12. Karasneh, B., Chaudron, M.R.: Img2uml: A system for extracting uml models from images. In: *Soft. Eng. and Adv. App.* pp. 134–137. IEEE (2013)
13. Kiryati, N., Eldar, Y., Bruckstein, A.M.: A probabilistic hough transform. *Pattern recognition* 24(4), 303–316 (1991)
14. Lank, E., Thorley, J., Chen, S., Blostein, D.: On-line recognition of uml diagrams. In: *Document Analysis and Recognition.* pp. 356–360. IEEE (2001)
15. Louloudis, G., Gatos, B., Pratikakis, I., Halatsis, C.: Text line and word segmentation of handwritten documents. *Pattern Recognition* 42(12), 3169–3183 (2009)
16. Mörzinger, R., Schuster, R., Horti, A., Thallinger, G.: Visual structure analysis of flow charts in patent images. In: CLEF’12 (2012)
17. Nagy, G.: Twenty years of document image analysis in pami. *IEEE Transactions on Pattern Analysis and Machine Intelligence* 22(1), 38–62 (2000)
18. Rago, A., Marcos, C., Díaz-Pace, J.A.: Uncovering quality-attribute concerns in use case specifications via early aspect mining. *Req. Eng.* 18(1), 67–84 (2013)
19. Rusinol, M., de las Heras, L.P., Mas, J., Terrades, O.R., Karatzas, D., Dutta, A., Sánchez, G., Lladós, J.: Flowchart recognition task. In: CLEF’12 (2012)
20. Smith, R.: An overview of the tesseract ocr engine. In: *ICDAR.* vol. 7, pp. 629–633 (2007)
21. Thean, A., Deltorn, J.M., Lopez, P., Romary, L.: Textual summarisation of flowcharts in patent drawings. In: CLEF’12 (2012)